

RICAMBI - SPARE PARTS - PIECES DETACHEES

LAVASTOVIGLIE / LAVAOGGETTI

DISHWASHERS / UTENSIL WASHER

LAVE VAISSELLES / LAVE UTENSILES



4SC

LAVASTOVIGLIE - DISHWASHERS - LAVE VAISSELLE - GESCHIRRSPUELER - LAVAPLATOS

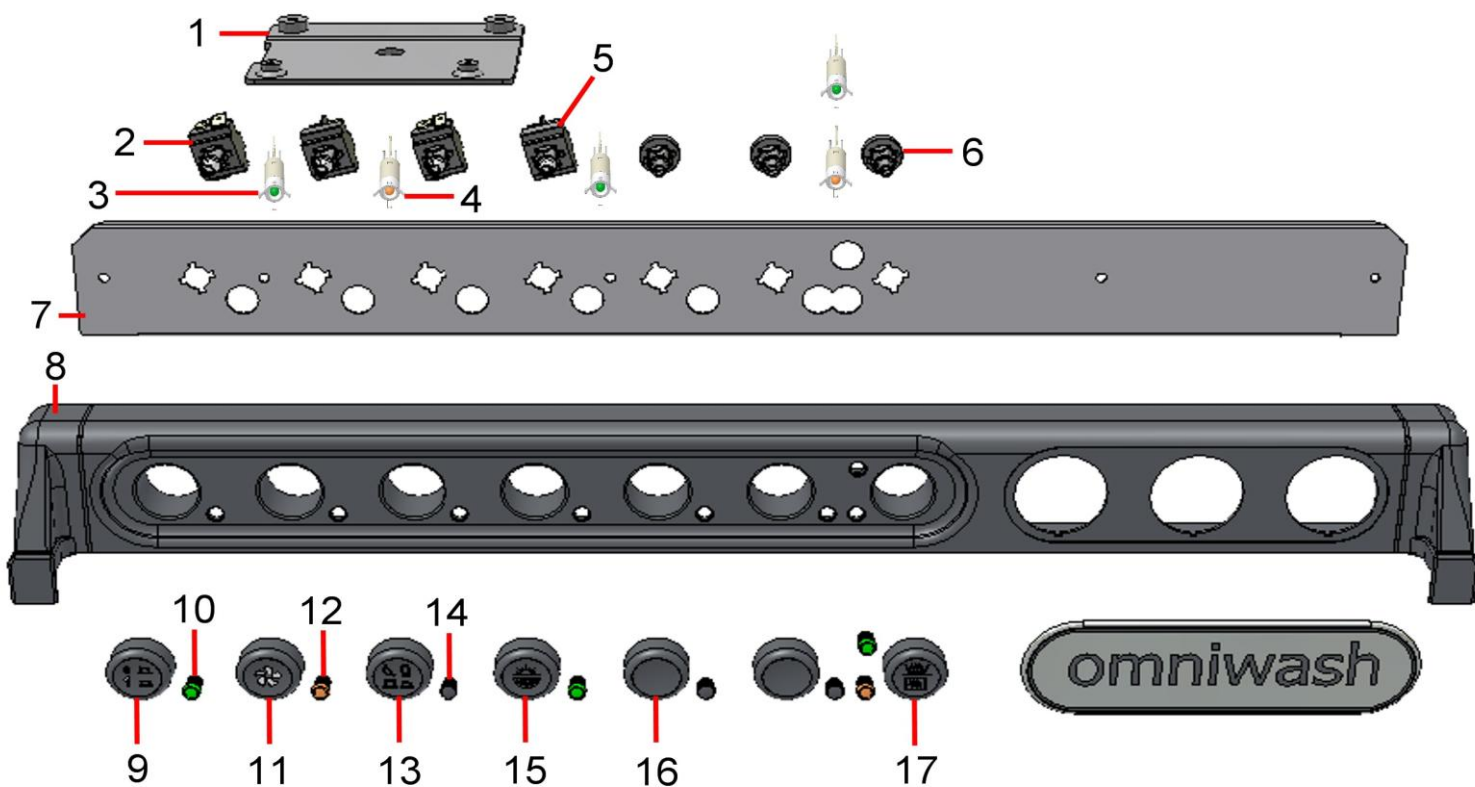

Pos.	Codice	Descrizione	Description	Description
1	CEPPPC	Piastra prolunga pannello comandi	Extension for component tray	Rallonge plaque composants électriques
2	CEDPPFD	Deviatore bipolare	Inner switch bipolar	Deviateur bipolaire
3	CESPV6	Lampada verde 6mm	Lamp assy, green, 6mm	Ampoule vert, 6mm
4	CESPA6	Lampada arancio 6mm	Lamp assy, orange, 6mm	Ampoule orange, 6mm
5	CEPBPF	Pulsante bipolare	Inner push botton bipolar	Bouton bipolaire
6	CETP25SF	Supporto tasto fisso	Support for indicator button	Support bouton fix
7	GMPI5D25SFRDP	Portainterruttori inox	Steel inner control panel	Porte-interrupteur inox
8	CEPC5D25QGR	Pannello comandi	Control panel, plastic, grey	Panneau de controle, plastic, gris
9	CETP25G01	Tasto tondo grigio "0-1"	On/off button, round, grey	Bouton rond gris "0-1"
10	CEGV6	Gemma verde 6mm	Lens, green, 6mm	Voyant vert, 6mm
11	CETP25GPC	Tasto tondo grigio "partenza ciclo"	Cycle start button, round, grey	Bouton rond gris "depart cycle"
12	CEGA6	Gemma arancio 6mm	Lens, orange, 6mm	Voyant orange, 6mm
13	CETP25GLV	Tasto tondo grigio "lento veloce"	Cycle selector button, round, grey	Bouton rond gris "lent/rapide"
14	CETP6GR	Tappo spia grigio 6mm	Cap, warning light, grey	Bouchon gris, 6mm
15	CETP25GRF	Tasto tondo grigio "risciacquo freddo"	Cold rinse button, round, grey	Bouton rond gris "rinçage froid"
16	CETP25GR	Tasto tondo grigio "tappo"	Button, round, grey (cap)	Bouton rond gris "Bouchon"
17	CETP25GRRS	Tasto tondo grigio "resistenze"	Heater indicator button, round, grey	Bouton rond gris "résistances"

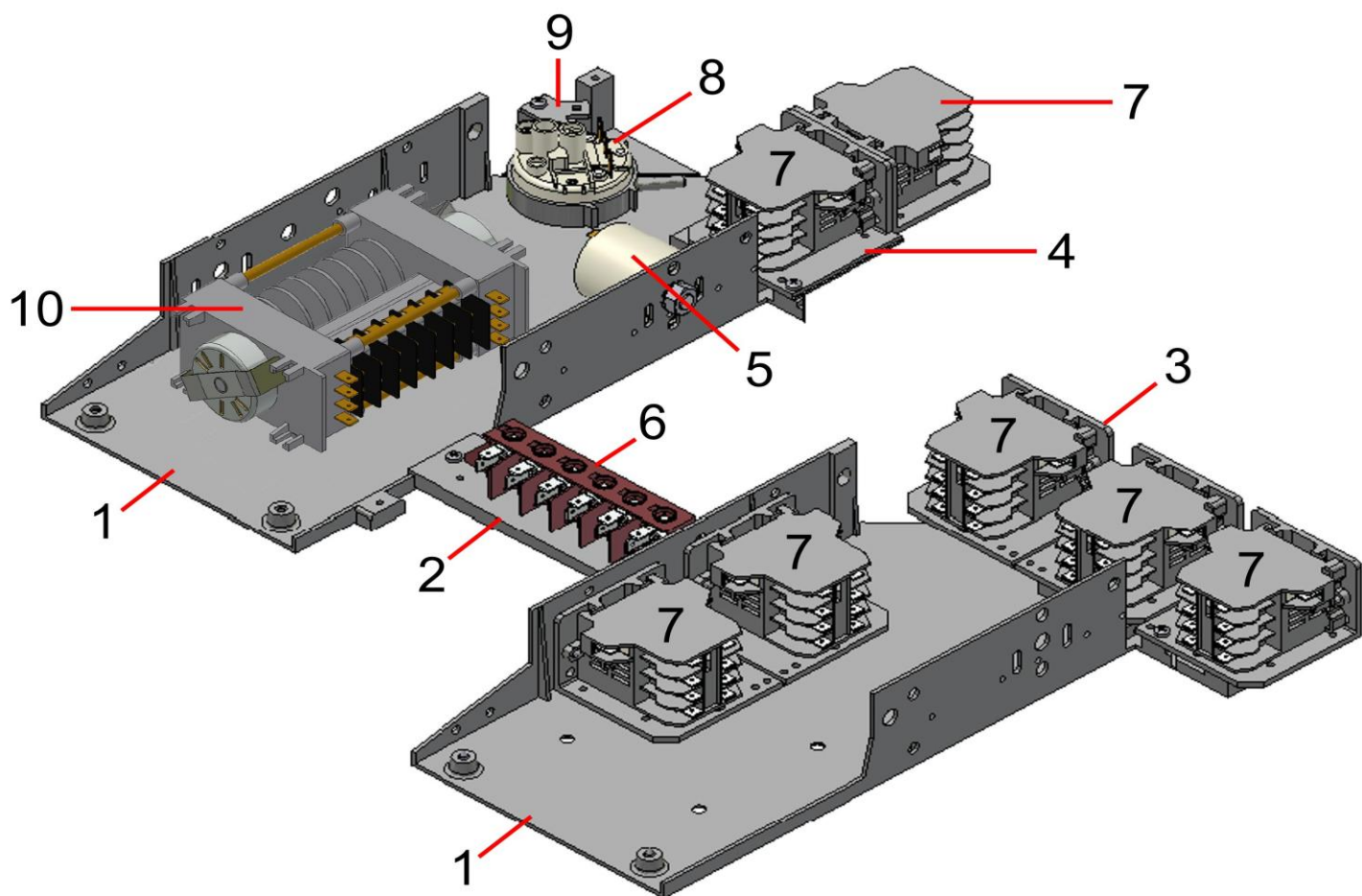

Pos.	Codice	Descrizione	Description	Description
1	CEPCE	Piastra cablaggio	Component tray	Plaque composants electriques
2	CEPFM	Piastrina fissaggio morsettiera	Mounting plate for terminal block	Plaquette fixation bornier
3	AM05SRTL2	Piastrina fissaggio 2 teleruttori	Double contactor bracket	Plaquette contacteur double
4	AM05SRTL1	Piastrina fissaggio 1 teleruttore	Contacteur bracket	Plaquette contacteur
5	CEFA	Filtro antisturbo	Suppressor	Filtre antiparasites
6	CEM0S3F	Morsettiera trifase	Main terminal block, 6-way	Bornier 3 phase
7	CECTF	Teleruttore	4-p contactor	Contacteur
8	CEPR62P	Pressostato 1 livello	Pressure switch	Pressostat, 1 niveau
9	AM0SQPR	Piastra pressostato	Bracket for pressure switch	Plaque support pressostat
10	CET3C4SC	Timer ciclo 120-240-360"	Cycle timer 120/240/360 sec.	Timer 120-240-360"

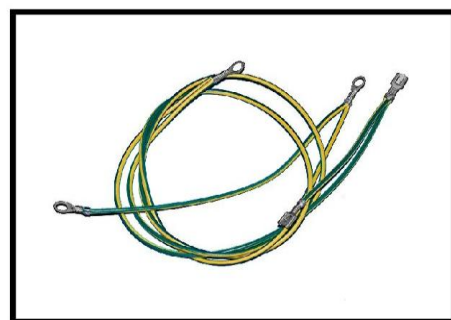
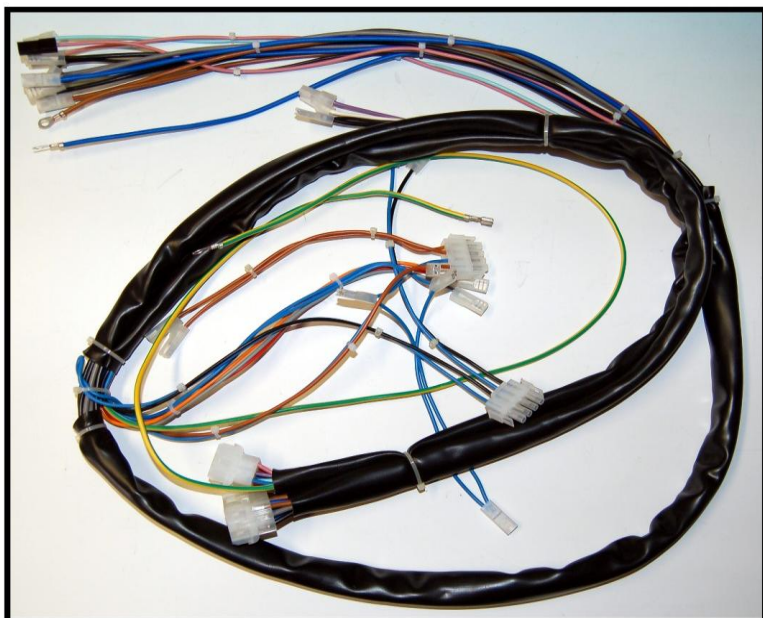
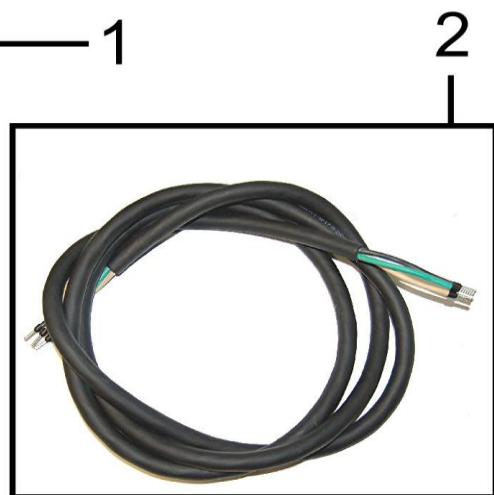
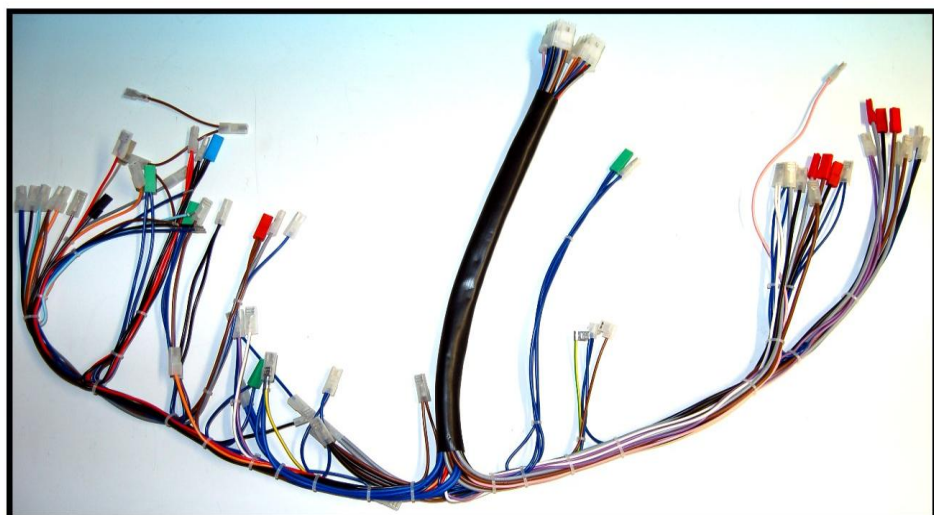

Pos.	Codice	Descrizione	Description	Description
1	CECBS4SC	Cablaggio superiore	Upper loom	Cablage superieur
2	CECE353F	Cavo alimentazione trifase	Electric supply cable - 3ph	Cable d'alimentation, 3ph
3	CECBCTTA	Catenaria circuito terra "TA"	Catenary, loom, ground	Cable de circuit à la terre
4	CECBI4SC	Cablaggio inferiore	Lower loom	Cablage inférieur

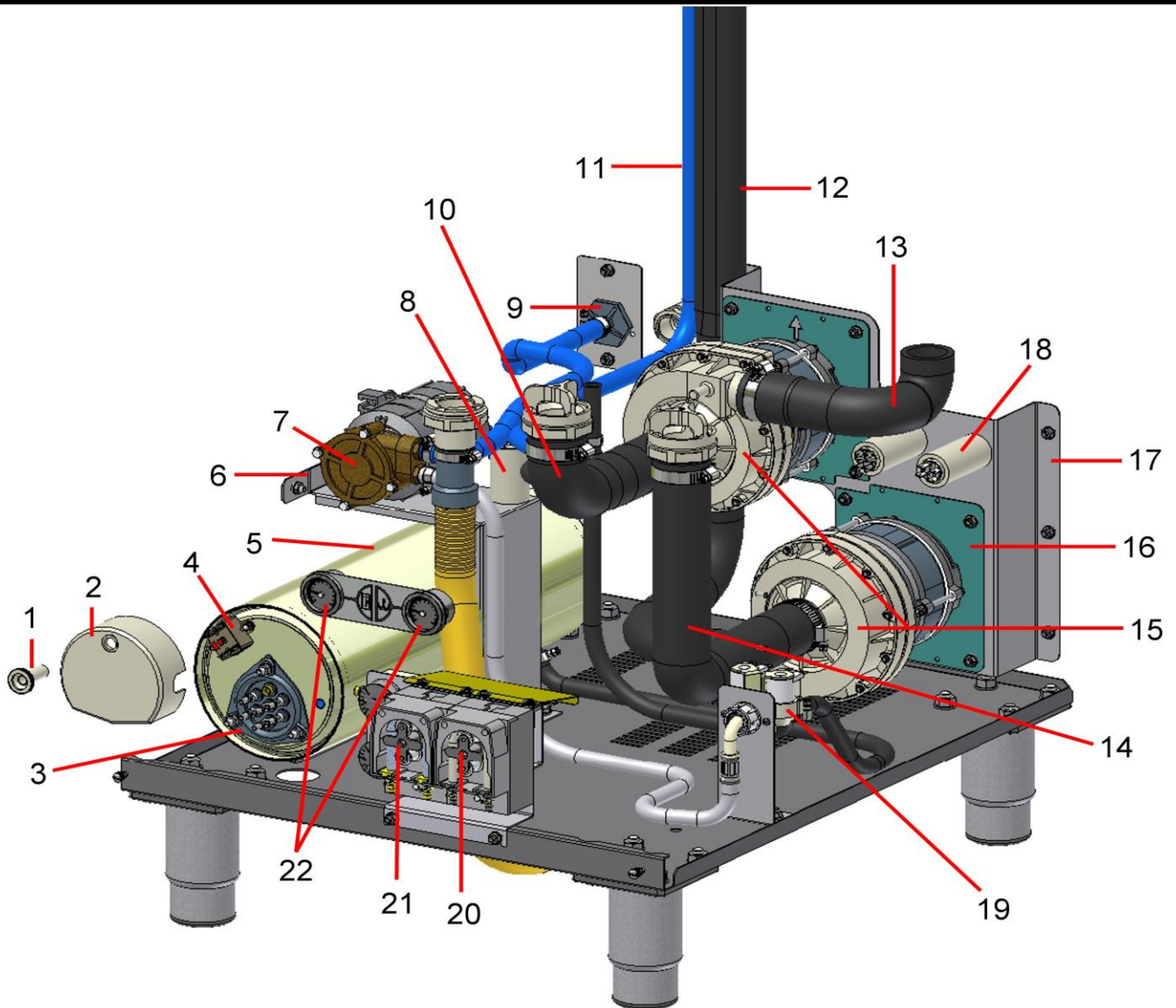

Pos.	Codice	Descrizione	Description	Description
1	GB083FV0	Protezione resistenza boiler	Rinse element guard, large	Protection résistance surchauffeur
2	GB093FV0	Nottolino protezione resistenza boiler	Retaining nut, rinse element, large	Ecrou fixation protection
3	CERB903F	Resistenza boiler trifase 9000W	Rinse element, 9.0 kw, 3ph	Résistance surchauffeur 9000 W
4	CESB454	Termostato sicurezza boiler	Rinse safety thermal switch	Termostat sécurité surchauffeur
5	GB413FNT	Boiler trifase	Boiler, 3ph	Surchauffeur, 3phase
6	GMSTFP5035	Staffa inox per pompa	Pump mounting braket	Joint inox pompe
7	CEPAPC4035	Pompa aumento pressione	Booster pump	Pompe hausse pression
8	CECN10	Condensatore 10 MF	Capacitor 10 MF	Condensateur 10 MF
9	ABRE34	Raccordo entrata carico	Adaptor	Raccord
10	GA38	Manicotto aspirazione	Inlet hose	Manchon aspiration lavage
11	TG1119FDA	Tubo gomma 11x19	Standard rinse hose 11x19mm	Tuyau caoutchouc 11x19 mm
12	LIS4SC39206	Manicotto mandata superiore	Complete wash outlet hose, upper	Durite de refoulement, superieur
13	LI4SAINF	Manicotto mandata inferiore	Wash outlet hose, lower	Durite de refoulement, inferieur
14	GASA8	Manicotto aspirazione	Wash inlet hose lower pump	manchon aspiration lavage, superieur
15	EP100C	Elettropompa 1hp 230v 50hz chiusa	Wash pump complete, closed nipple	Pompe de lavage 1hp, raccord fermé
16	AM0SQFP6	Piastra sostegno pompa	Washpump mounting plate	Plaque fixation pompe
17	GMSTFPL4SC	Omega supporto elettropompe	Washpump support plate	Support pompe de lavage
18	CECN12	Condensatore 12 MF	Capacitor 12 MF	Condensateur 12 MF
19	CEEV2	Elettrovalvola 2 vie 220 volt	Solenoid Valve, 2-Way, 230V	Electrovanne 2 voies 220 volt
20	D0SDDETLE	Dosatore detergente "eur"	Soap pump	Doseur produit de lavage "eur"
21	D0SBRIETLE	Dosatore brillantante "eur"	Rinse-aid pump housing	Doseur produit rinçage "eur"
22	CETERC	Termometro	Thermometer	Thermometre

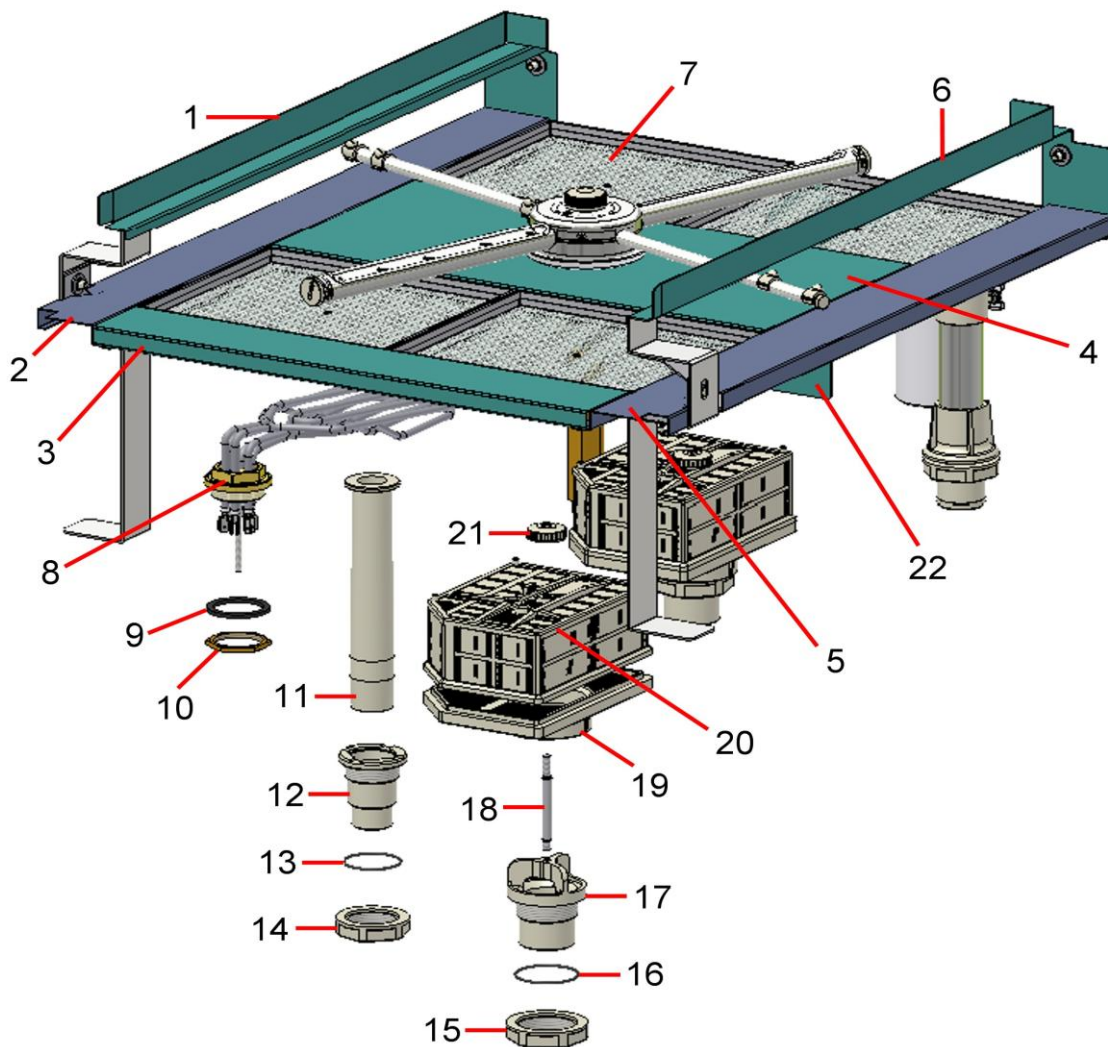

Pos.	Codice	Descrizione	Description	Description
1	GMGC4SCSXI	Guida supporto cestello sinistra	Basket ramp guide strip, LH	Guide panier gauche
2	LISFLS4SC	Supporto laterale sinistro filtri superficie	Basket ramp, LH	Support panier gauche
3	LISFA4SA	Supporto anteriore filtri superficie	Front filter support	Support anterieur filtres
4	LISFC4SC	Supporto centrale filtri superficie	Central filter support	Support centrale filtres
5	LISFLD4SC	Supporto laterale destro filtri superficie	Basket ramp, RH	Support panier droit
6	GMGC4SCDXI	Guida supporto cestello destra	Basket ramp guide strip, RH	Guide panier droite
7	LIF4V4C	Filtro superficie inox completo	Top filter section, steel	Filtre de surface, inox, complet
8	CERV453F	Resistenza vasca 4500/3w trifase	Wash element, 4.5 kW, 3-loop	Resistance de cuve 4500W 3phases
9	G50403GT	Guarnizione resistenza vasca trifase	Wash element seal	Joint resistance cuve
10	D0114	Dado 1"1/4	Brass nut 1 1/4"	Écrou serrage 1 1/4"
11	GS6013B	Troppo pieno	Drain plug or standpipe	Trop-plein
12	GS317B	Piletta scarico vasca	Drain boss	Bonde de vidange
13	OR3168	Or 3168	O ring 3168	Joint Or 3168
14	DP114	Dado 1"1/4 gas	Plastic nut	Écrou plastique pour bonde
15	DP112	Dado 1"1/2 gas	Plastic nut 1"1/2	Écrou plastique pour bonde 1"1/2
16	OR3187	Or 3187	O ring 3187	Joint Or 3187
17	GA311B	Piletta aspirazione	Filter boss	Bonde d'aspiration
18	GA61220T	Tirante filtro	Filter retaining rod	Tige de filtre
19	GA315RAV0	Piastra inferiore filtro aspirazione "VO"	Wash filter base,VO	Plaque filtre d'aspiration, "VO"
20	GA315RV0	Filtro aspirazione "VO"	Wash filter body, VO	Filtre d'aspiration, "VO"
21	GA013B	Ghiera fissaggio filtro aspirazione	Filter retaining nut	Écrou de filtre
22	LISFP4SANT	Supporto posteriore filtri superficie	Rear filter support	Support posterieur filtres

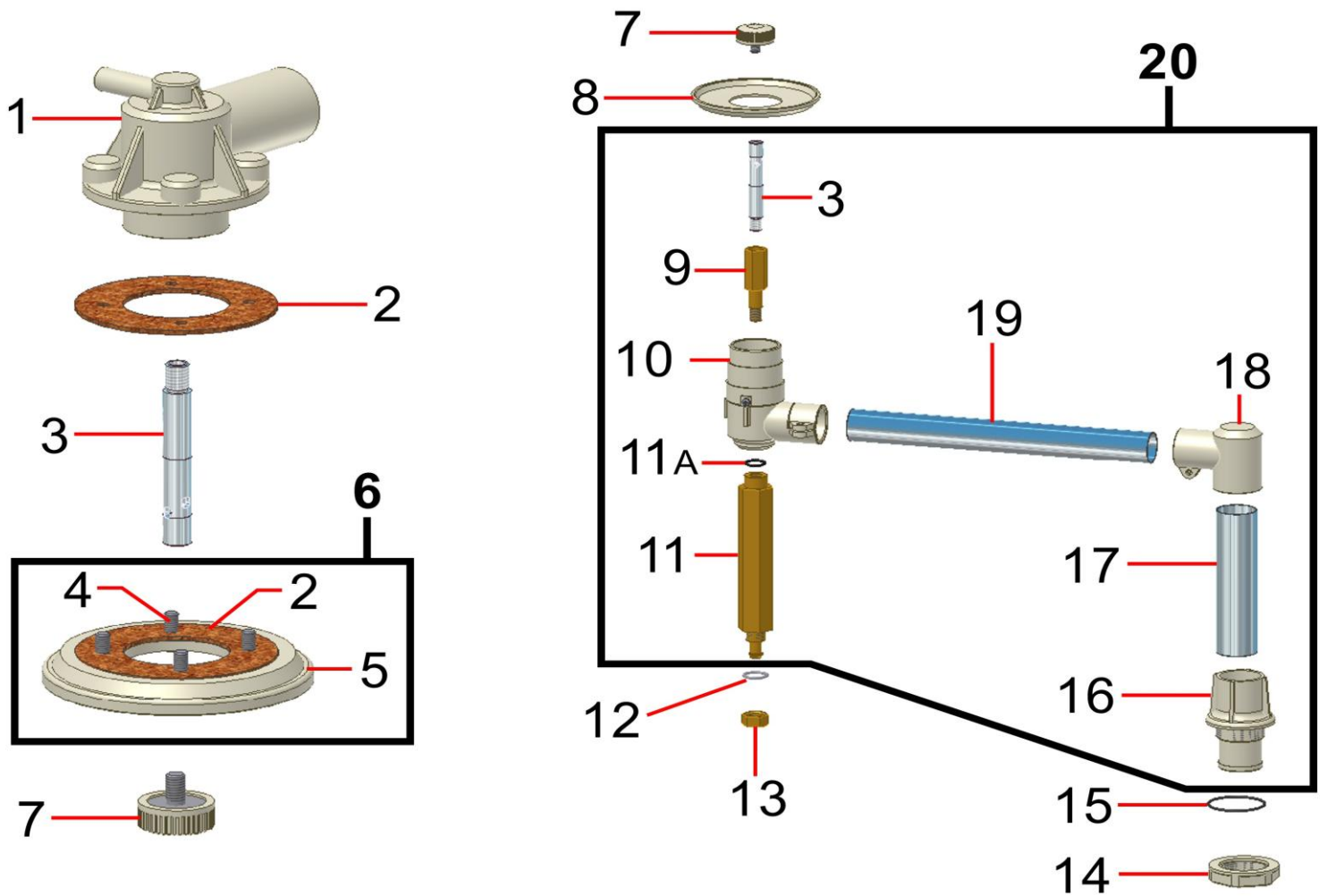

Pos.	Codice	Descrizione	Description	Description
1	LS5B	Supporto superiore	Top boss	Support supérieur
2	LS02	Guarnizione supporto superiore	Cork seal	Joint
3	LS08	Perno inox lungo	Wash spindle	Pivot inox
4	VVTSEI616I	Vite 6x16	Screw, 6x16	Vis, 6x16
5	LS03P	Ghiera superiore	Baffle plate	Défecteur
6	LS03PC	Ghiera superiore assemblata	Baffle plate	Défecteur
7	LS09PB	Nottolino fissaggio girante	Spindle retaining screw	Ecrou pour pivot
8	LI034	Ghiera inferiore inox	Deflector disk inox	Défecteur inox
9	LI330	Prolunga perno inox	Spindle extension	Extension pivot
10	LI029CAB	Supporto inferiore	Bottom boss assy	Support inférieur
11	LISA33F	Supporto risciacquo	Lower support column	Support rinçage
11A	VRP10I	Rondella piana Ø 10	Washer Ø 10	Rondelle Ø 10
12	OR122	Or supporto risciacquo	O-ring 122	O-ring
13	D038A	Dado ottone 3/8	Brass lock nut 3/8"	Ecrou 3/8"
14	DP112	Dado 1"1/2 gas	Plastic nut 1"1/2	Écrou plastique pour bonde 1"1/2
15	OR3181	Or 3181	O ring 3181	Joint Or 3181
16	LI4SAFC	Piletta entrata	Wash inlet elbow	Bonde entrée
17	LISA26A	Tubo inox piletta entrata	Stainless steel Wash inlet cable	Tuyau inox bonde entrée
18	LI027	Raccordo entrata	Inlet elbow	Raccord entrée
19	LI428PR5	Tubo inox interno	Spacer tube	Tuyau inox
20	GLICQ4SCBCOMP	Gruppo completo assemblato	Lower elbow and boss assy complete	Groupe assemblé

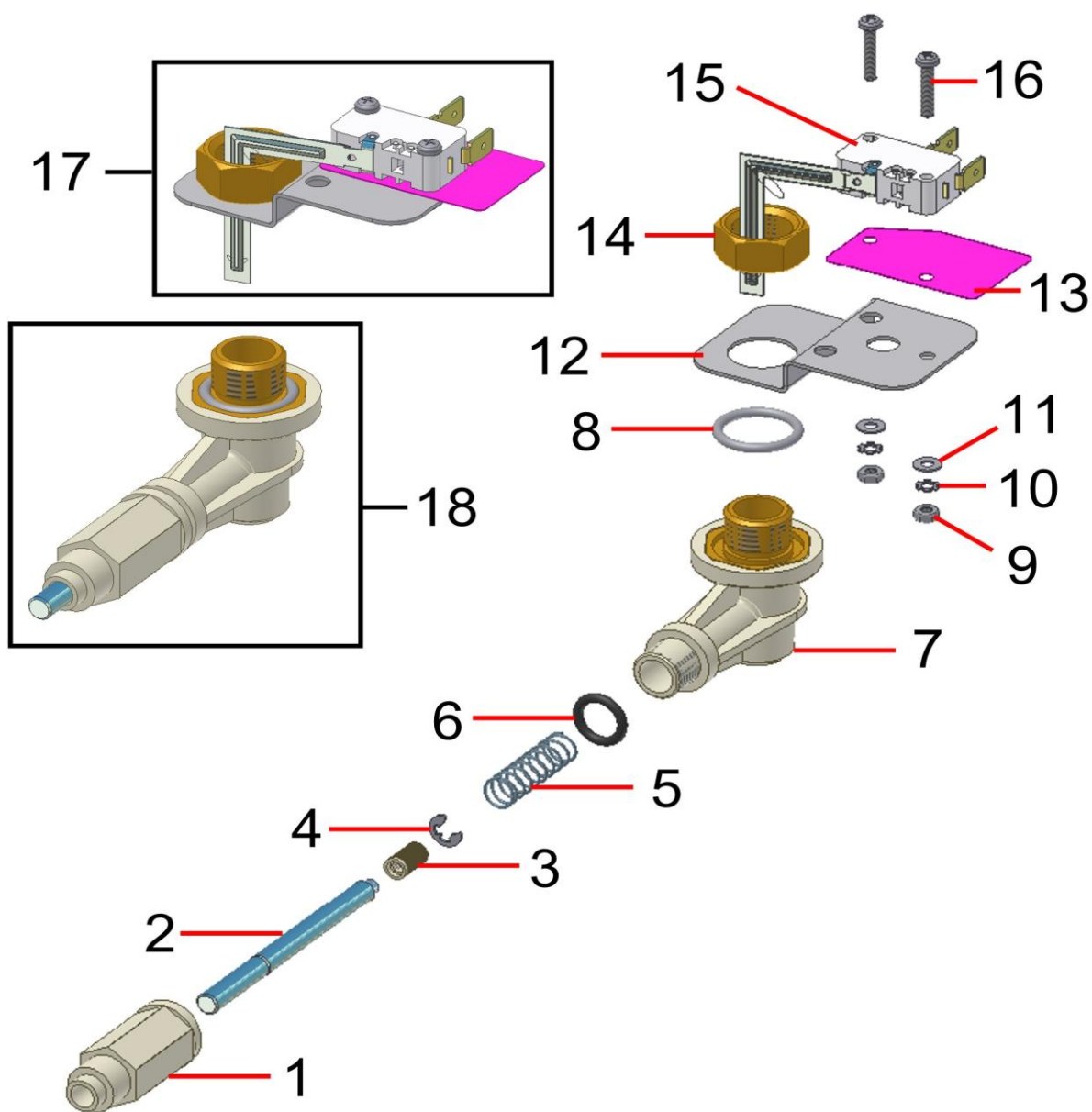

Pos.	Codice	Descrizione	Description	Description
1	CEMP23B	Corpo anteriore sicurezza porta	Door plunger body	Corps antérieur
2	CEMP21	Astina sicurezza porta	Push rod	Tige sécurité porte
3	CEMPPIB	Puntale isolante astina sicurezza porta	Push rod end cap	Poussoir plastique
4	CEMP22	Seeger astina sicurezza porta	Circlip	Circlips
5	CEMP20	Molla sicurezza porta	Door plunger spring	Ressort sécurité porte
6	OR4036	Or sicurezza porta	O ring 4036	Joint OR 4036
7	CEMP18B	Corpo posteriore sicurezza porta	Door plunger elbow	Corps postérieur
8	OR122	Or 122	O-ring 122	O-ring 122
9	VD3I	Dado M3	Nut	Ecrou
10	VR3I	Rondella dentellata ø 3	Tab washer D. 3	Rondelle à denture, d. 3
11	VRGB3I	Rondella grembialina ø 3	Steel rod	Rondelle, d. 3
12	CEMP13CS	Squadretta micro porta standard	Bracket for door switch	Support interrupteur
13	CEISOMPNT	Isolante micro porta	Insulating plate	Isolant
14	D038A	Dado ottone 3/8"	Brass lock nut 3/8"	Ecrou 3/8"
15	CEMP12CS	Microinterruttore con leva	Door micro switch	Micro interrupteur CS
16	VVTCC316I	Vite M3x16	Screw M3x16	Vis, M3x16
17	CEMP12CSC	Microinterruttore standard completo	Door switch assy complete	Micro contact porte complet
18	CEMP1823B	Sicurezza porta completa	Door plunger assembly	Sécurité de porte assemblée

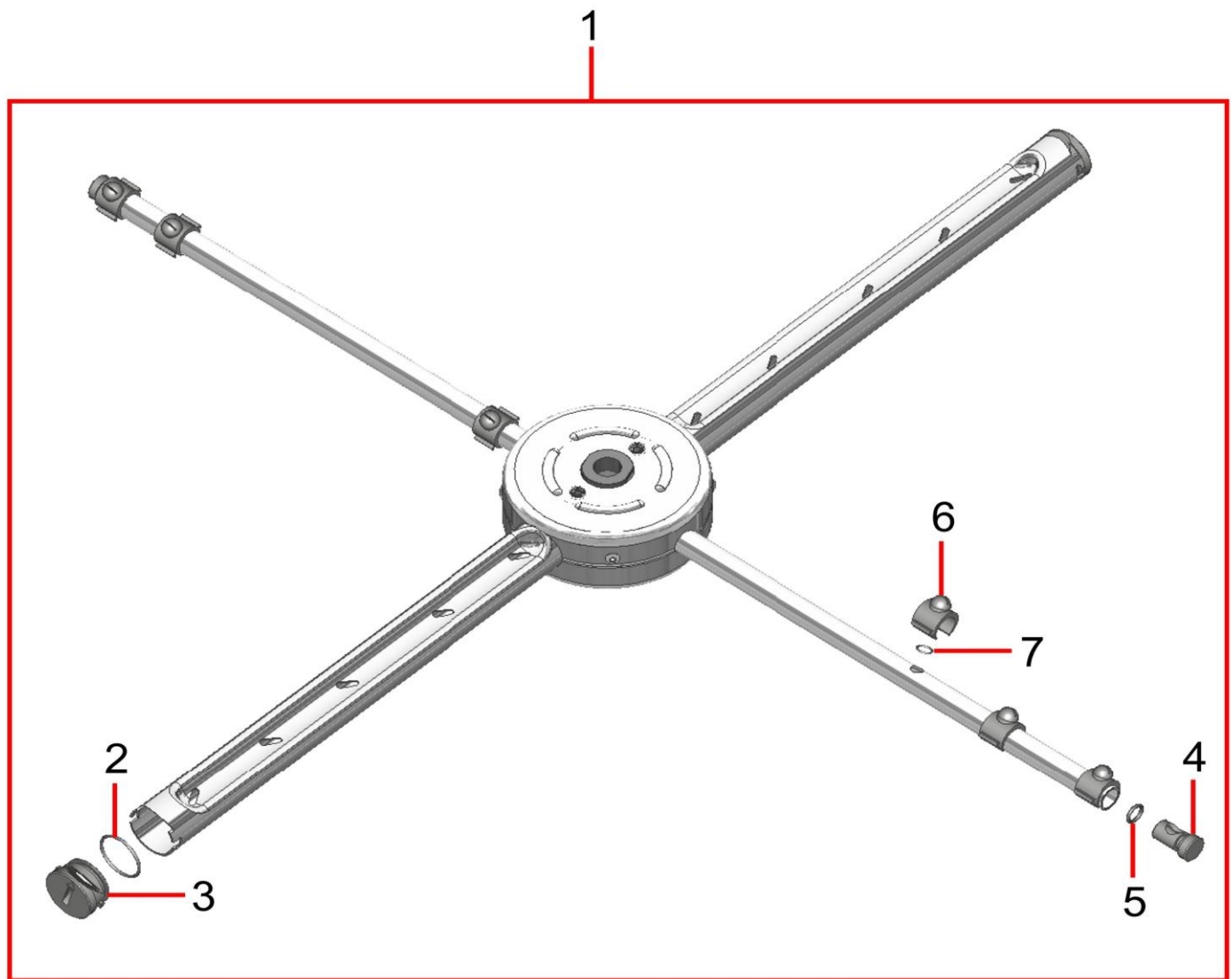

Pos.	Codice	Descrizione	Description	Description
1	LSI4SCI09C	Girante inox completa assemblata	Rotating stainless steel wash assy complete	Couronne complete en acier inox
2	OR20515	Or 20,5 x 1,5	Or 20,5 x 1,5	Joint torique 20,5 x 1,5
3	LSI018GIGLFB	Tappo asta lavaggio inox	Stainless steel wash arm plug	Bouchon inox rampe lavage
4	GR019GB	Tappo asta risciacquo	Rinse arm plug	Bouchon rampe rinçage
5	OR106	Or 106	Or 106	Joint torique 106
6	LSI020GIB	Getto risciacquo	Rinse jet	Gicleur rinçage
7	OR5501	Or 5,5 x 1	Or 5,5 x 1	Joint torique 5,5 x 1

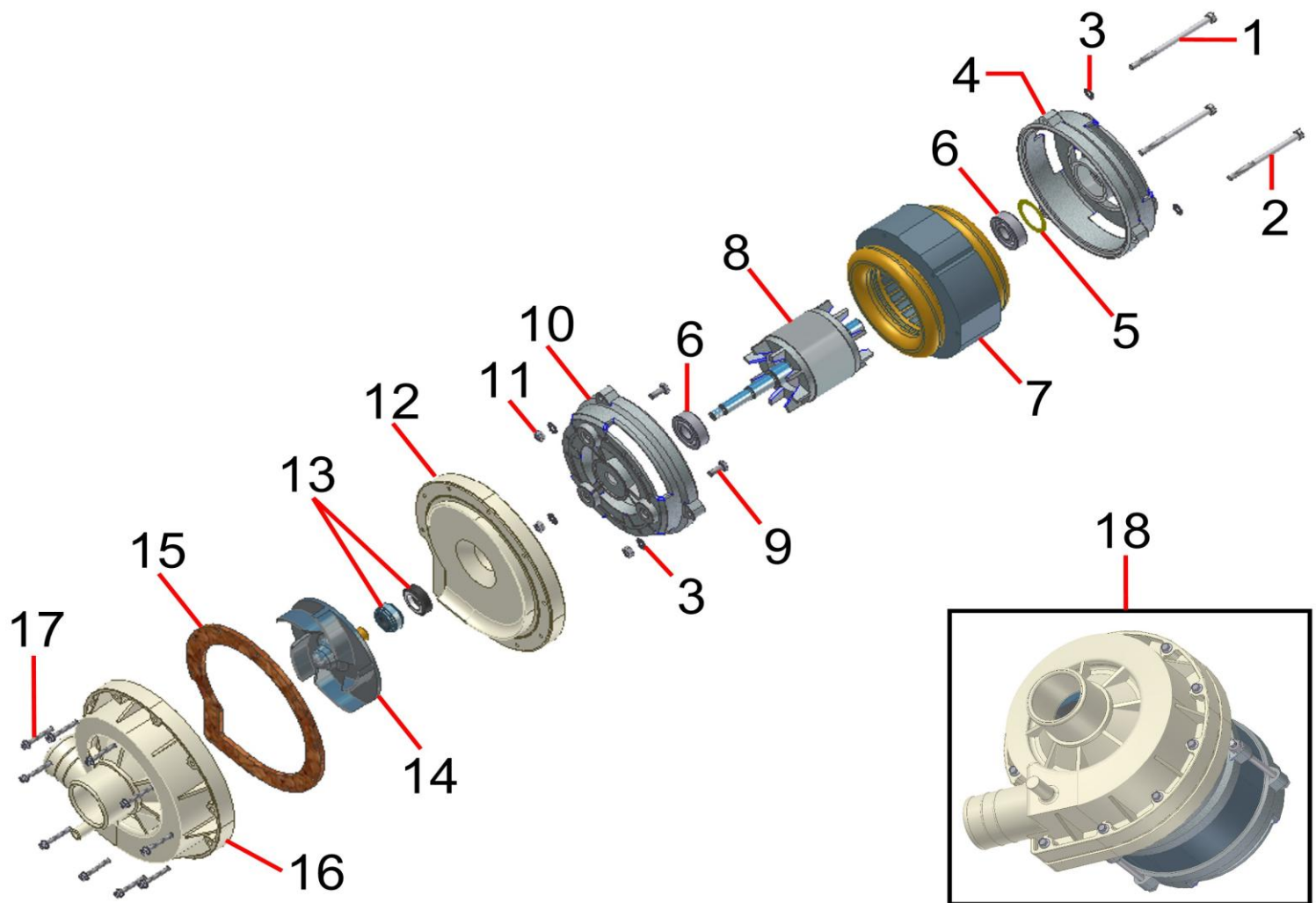

Pos.	Codice	Descrizione	Description	Description
1	VVTE580Z	Vite TE 5x80	Special screw for motor assy, 5x80	Vis 5x80
2	VVTE570Z	Vite TE 5x70	Special screw for motor assy, 5x70	Vis 5x70
3	VR5I	Rondella dentata diam 5	Special tab washer	Rondelle éventailé diam. 5 mm
4	EP05M5	Calotta alluminio (filettata)	Motor endplate NDE	Calotte aluminium pompe
5	EP011	Anello compensazione pompa	Bearing ring	Boucle compensation pompe
6	EP07	Cuscinetto per motore pompa	Motor bearing	Roulement pour moteur pompe
7	EP7510	Statore avvolto	Stator	Stator pompe
8	EP7589	Rotore con albero	Rotor	Rotor de compression
9	VVTE512I	Vite 5x12	Special screw	Vis 5x12
10	EP05	Calotta alluminio	Motor endplate DE	Calotte aluminium pompe
11	VD5I	Dado esagonale m 5	Special hexagon nut	Ecrou M5
12	EP755TP	Fondo pompa grande	Impellor back plate	Fond pompe
13	EP04	Anello tenuta	Rotating shaft seal	Presse étoupe
14	EP753	Girante pompa grande	Impellor	Turbine de pompe 1hp
15	EP752NT	Guarnizione pompa	Cork gasket	Joint pompe
16	EP751TPC	Corpo pompa grande chiuso	Impellor housing, closed nipple	Corps pompe 1hp, raccord fermé
17	VATE4232Z	Vite autofilettante 4,2x32	Special screw	Vis 4,2x32
18	EP100C	Elettropompa 1hp 230v 50hz chiusa	Wash pump complete, closed nipple	Pompe de lavage 1hp, raccord fermé

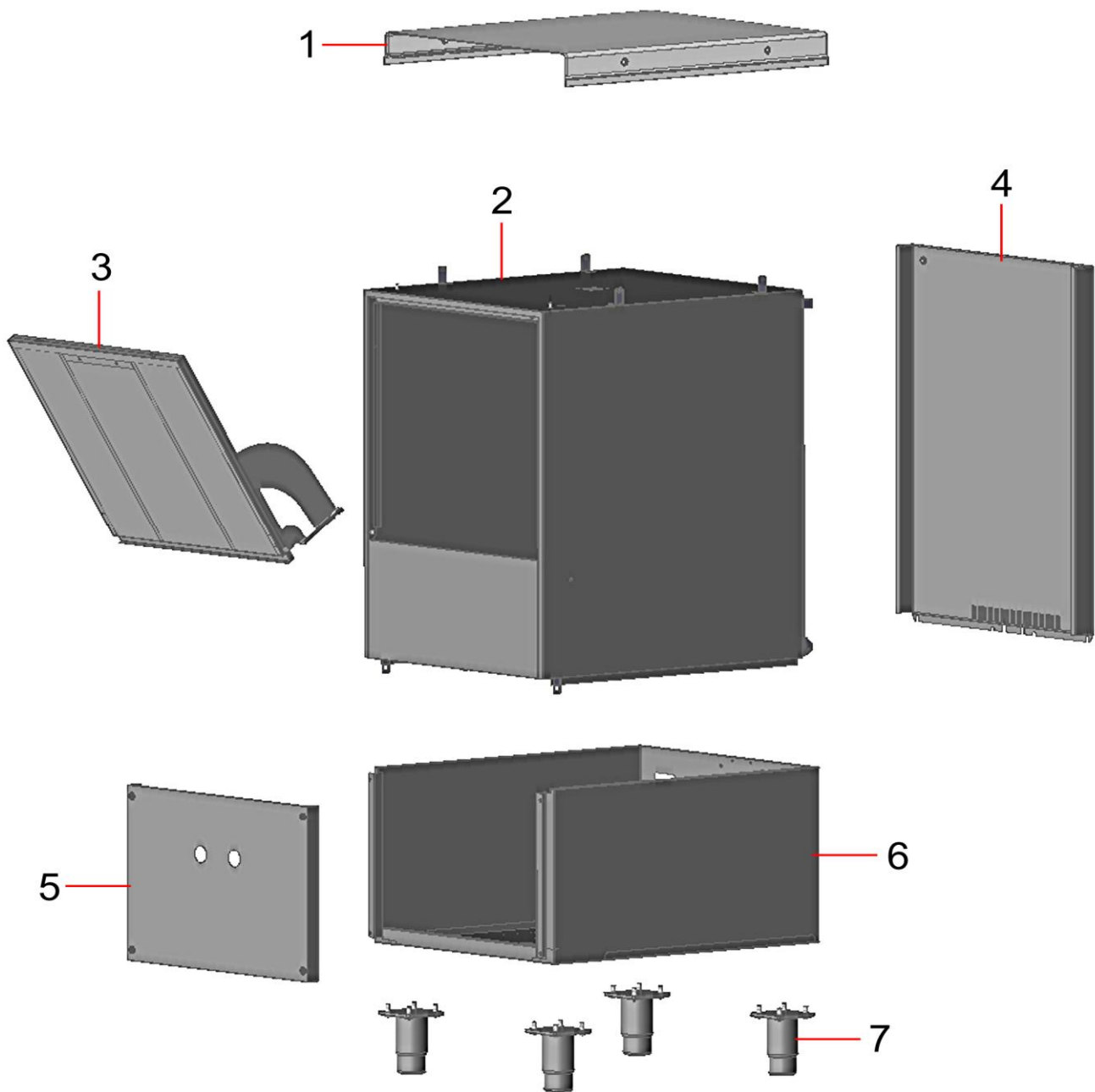

Pos.	Codice	Descrizione	Description	Description
1	GMPS4SCRDP	Pannello superiore	Top panel	Panneau supérieur
2	GMVA4SC	Vasca	Wash cabinet	Cuve
3	GMP04SC	Porta	Door	Porte
4	GMPP4SC	Pannello posteriore	Back panel	Panneau dosseret
5	GMCRB4SC	Cruscotto	Bottom panel	Panneau socle
6	GMBA4SC	Basamento	Base	Socle
7	AM0165BC	Piedino inox con viti	Adjustable foot	Pied

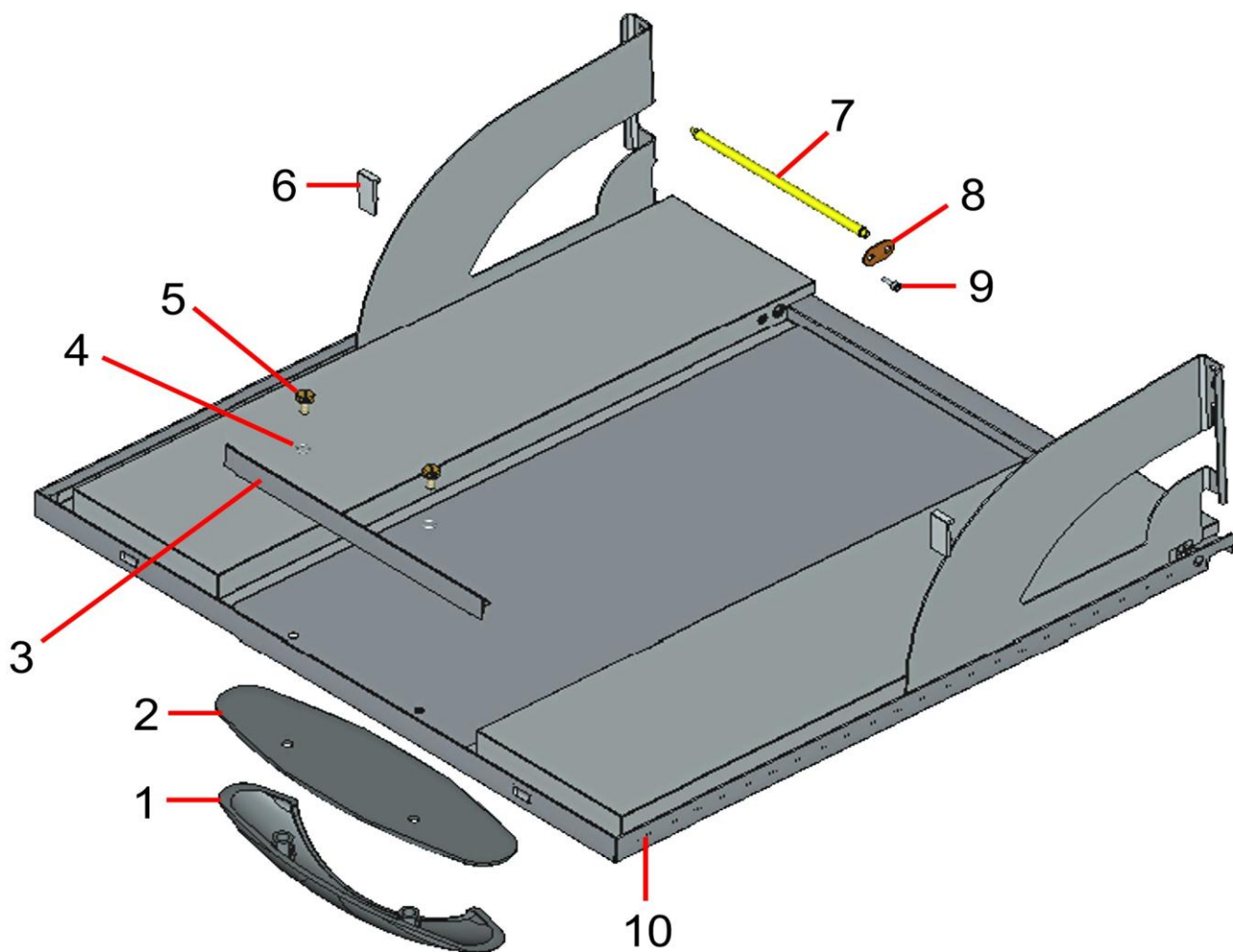

Pos.	Codice	Descrizione	Description	Description
1	AM010MD25GR	Maniglia chiusa ovale grigia	Handle, grey, thru grip, oval	Poignée porte grise
2	AM010CD25GR	Cornice sottomaniglia grigia	Handle backplate, grey, oval	Entourage sous-poignée, grise
3	GMDP2	Deflettore porta	Door deflector	Deflecteur porte
4	OR106	Or per vite maniglia	O-Ring, door handle screw	Joint torique pour poignée
5	VVSP6100	Vite maniglia	Screw, door handle fixing	Vis pour poignée porte
6	AMPCP	Paracolpo porta	Door stop	Pare-chocs
7	AM412NTM	Perno porta	Door pin spacer	Axe de la porte
8	AM0PFPPM	Piastrina fissaggio perno porta	Pin security plate	Plaquette tenue pivot porte
9	VVEI410I	Vite, 4x10 mm	Screw, 4x10 mm	Vis, 4x10 mm
10	GMP04SC	Porta	Door	Porte

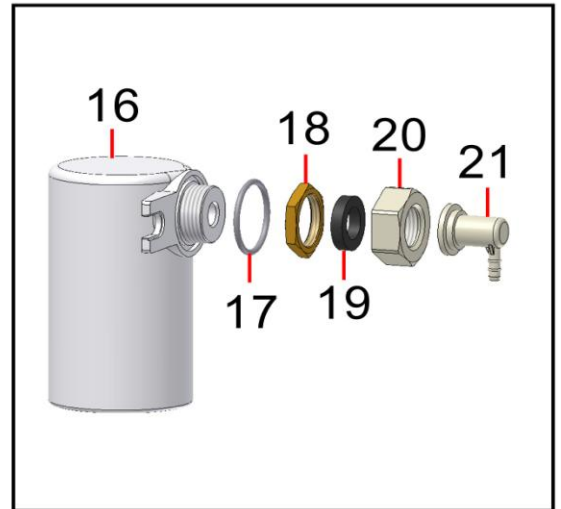
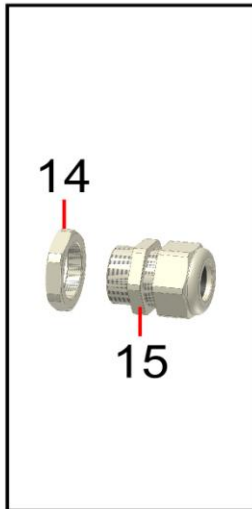
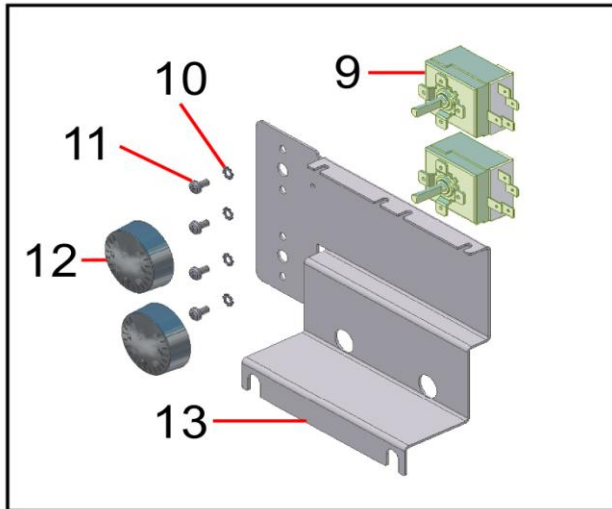
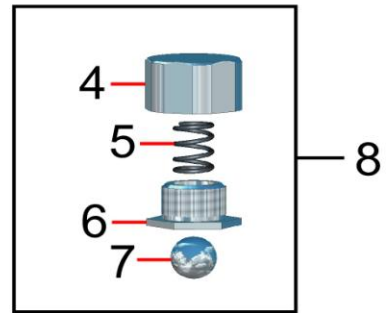
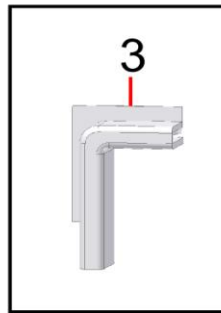
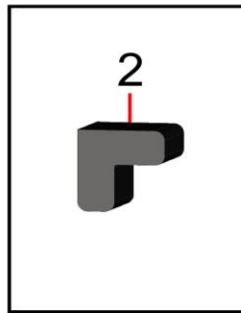
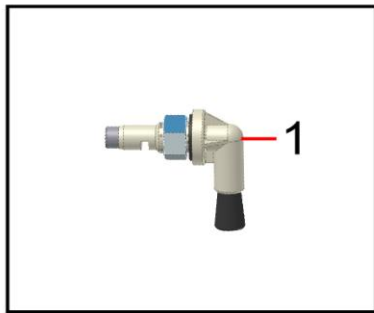

Pos.	Codice	Descrizione	Description	Description
1	DSDET040BC	Iniettore completo	Soap Elbow Assy	Injecteur completo
2	AM015	Angolare vasca gomma	Seal corner guard	Coint cuve , caoutchouc
3	AM014B	Angolare vasca plastica	Plastic corner guard	Coin extérieure, plastique
4	AM011A	Dado scrocchetto	Ball catch nut	Bouchon de la bille
5	AM011C	Molla scrocchetto	Ball catch spring	Ressort inox
6	AM011E	Sede sfera scrocchetto	Ball catch seat	Siège ressort inox
7	AM011D	Sfera scrocchetto	Ball catch ball	Bille inox
8	AM011	Scrocchetto completo	Door ball catch assy	Fermeture de porte
9	CETB85CAM	Termostato boiler regolabile (2008)	Adjustable control thermostat (2008)	Termostat surchauffeur réglable (2008)
10	VR4I	Rondella dentellata Ø 4	Tab washer	Rondelle à denture, d. 4
11	VVTCC48I	Vite fissaggio termostati	Fixing thermostat screw	Vis fixation thermstats
12	CEMTBCAM	Manopola termostato (2008)	Knob, thermostat (2008)	Manette thermostat (2008)
13	AM0SQFTDE46AB	Squadretta termostati	Bracket for thermostats	Fixage thermostats
14	CEFISPG21D	Ghiera fissacavo	Locating nut for cable	Ecrou serrage cable
15	CEFISPG21C	Corpo fissacavo	Cable gland locating nut	Gigleur écrou arrêt de cable
16	GP02562PB4SC	Trappola aria	Pressure vessel	Chambre de compression
17	OR3118	Or 3118	O-ring 3118	Joint 3118
18	D034	Dado 3/4	Brass nut, 3/4	Ecrou 3/4
19	G251525G	Guarnizione raccordo girevole	Sealing washer	Joint raccord tournant
20	GP026BB	Dado raccordo girevole	Air tap elbow nut	Ecrou pour raccord tournant
21	GP026AB	Raccordo girevole	Air trap elbow	Raccord tournant



1

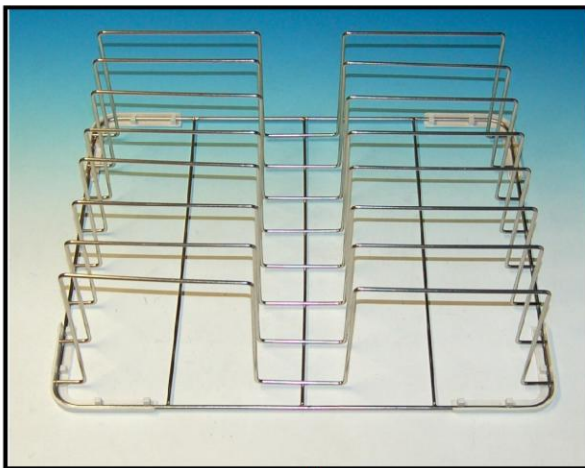

2

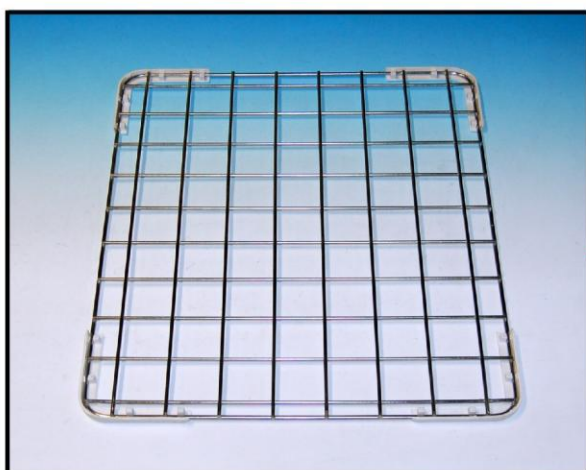

3



4



5

6

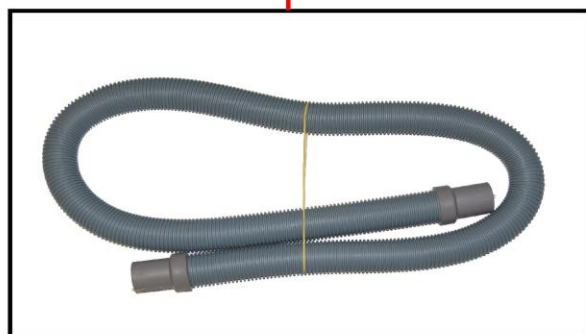

7



Pos.	Codice	Descrizione	Description	Description
1	CQ4SC635012GEN	Cestello inox 63x50x12	Stainless steel basket 63x50x12	Panier en acier inox 63x50x12
2	CQ4SC6049PT7	Cestello inox porta teglie 7 posti	Stainless steel tray rack - 7 places	Support pour plat à rôtir en acier inox
3	CQ4SC6050GRI	Griglia inox 60x50	Stainless steel grid 62x50cm	Grille en acier inox 62x50
4	CECV612PSC	Confezione cavallotti	Connection pack	Fils pour changement liaison électrique
5	D0SVFFC	Valvola di fondo con filtro	Foot valve with filter	Clapet avec filtre
6	GS330	Tubo scarico Ø 31,5	Drain Pipe Diam 31,5	Flexible de vidange Ø 31,5
7	TC34	Tubo carico "vde" mt. 2	Water Supply Hose, 3/4" BSP, 2 m	Tube entrée eau "vde" mt. 2

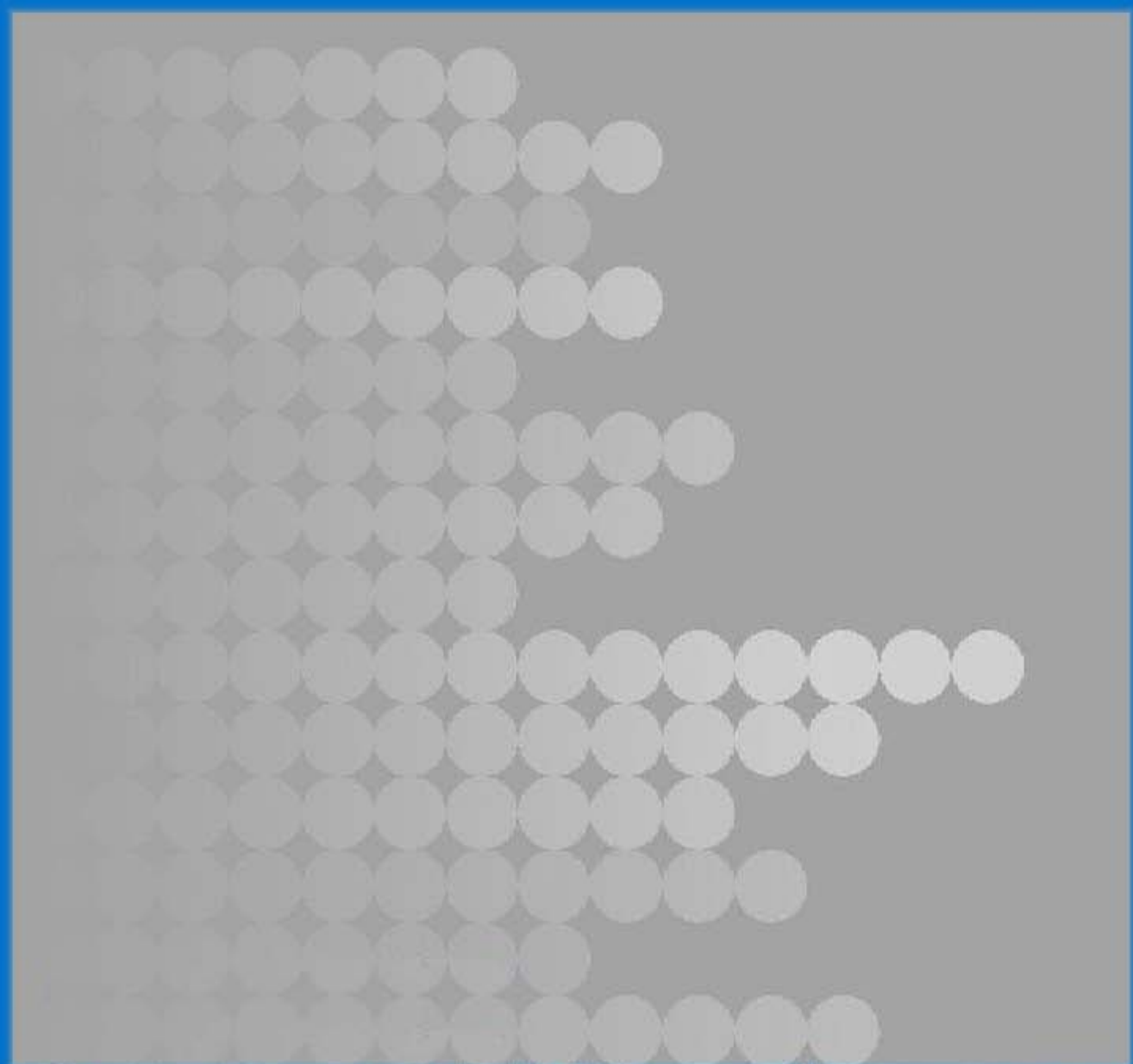

0110/108.00

